



**Hollymatic.**

*The Power Of The Dealer Network*

## Hollymatic 190 Automatic Feed Grinder

### Specifications:

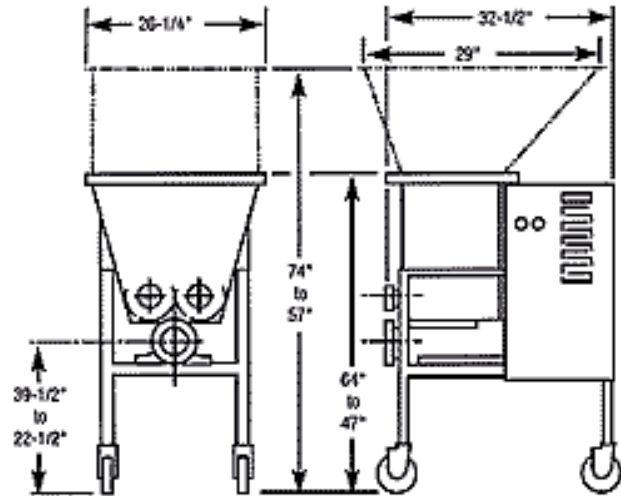

### Standard Features

- 7-1/2 Hp motor
- #52 head
- Swing-open tub
- Start/stop controls (available right or left hand)
- Interlock switch shuts off the 190 when lid is opened or optional extension is raised
- Inspection holes in lid
- Meat deflector
- Standard adjustable legs
- Four, heavy duty swivel lock casters Weight/640 lbs.

### Available Voltages

- 200 V., 3 Ph., 60 Hz., 25 A.
- 230/460 V., 3 Ph., 60 Hz., 22/11A.
- 575 V., 3 Ph., 60 Hz., 8.8A.
- 220/380 V., 3 Ph., 50 Hz., 24/14A.

### First Grind Performance

Production output: 3,200 to 6,500 lbs. per hour. Dependent on grinder plate size, reducer speed, and product.

### Optional Features

- Hopper extension
- Interlocked lid for hopper extension
- High elevation adjustable legs
- Feed screw speed:

- 120 RPM (15:1)
- 180 RPM (10:1)